



BLACK dynamic

Vehicle Keybenefit



Entspricht höchsten deutschen Qualitätsstandards



Patentiertes PowerFrame® Gitter für zuverlässige Startleistung, schnelle Ladefähigkeit und hohe Korrosionsbeständigkeit



Erfüllt die Anforderungen der OE als passendes Ersatzteil

For more information visit varta-automotive.com

ORDER INFORMATION

European Type No. (ETN):	570409064
Article Number:	5704090643122
Short Code:	E13
Barcode:	4016987119426
UK Code:	096
Packaging Unit:	1
Quantity per Pallet:	48

TECHNICAL INFORMATION

Voltage [V]:	12	Base Hold-down:	B13
Battery Capacity [Ah]:	70	Layout:	0
Cold Cranking Amps (CCA), EN [A]:	640	Terminal Types:	1
Length [mm]:	278	Case Size:	H6/LN3
Width [mm]:	175	Weight filled (kg):	16,6
Height [mm]:	190		

DRAWINGS

B13

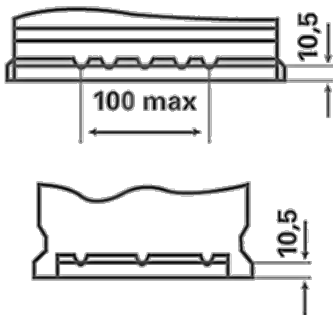

0



1

